

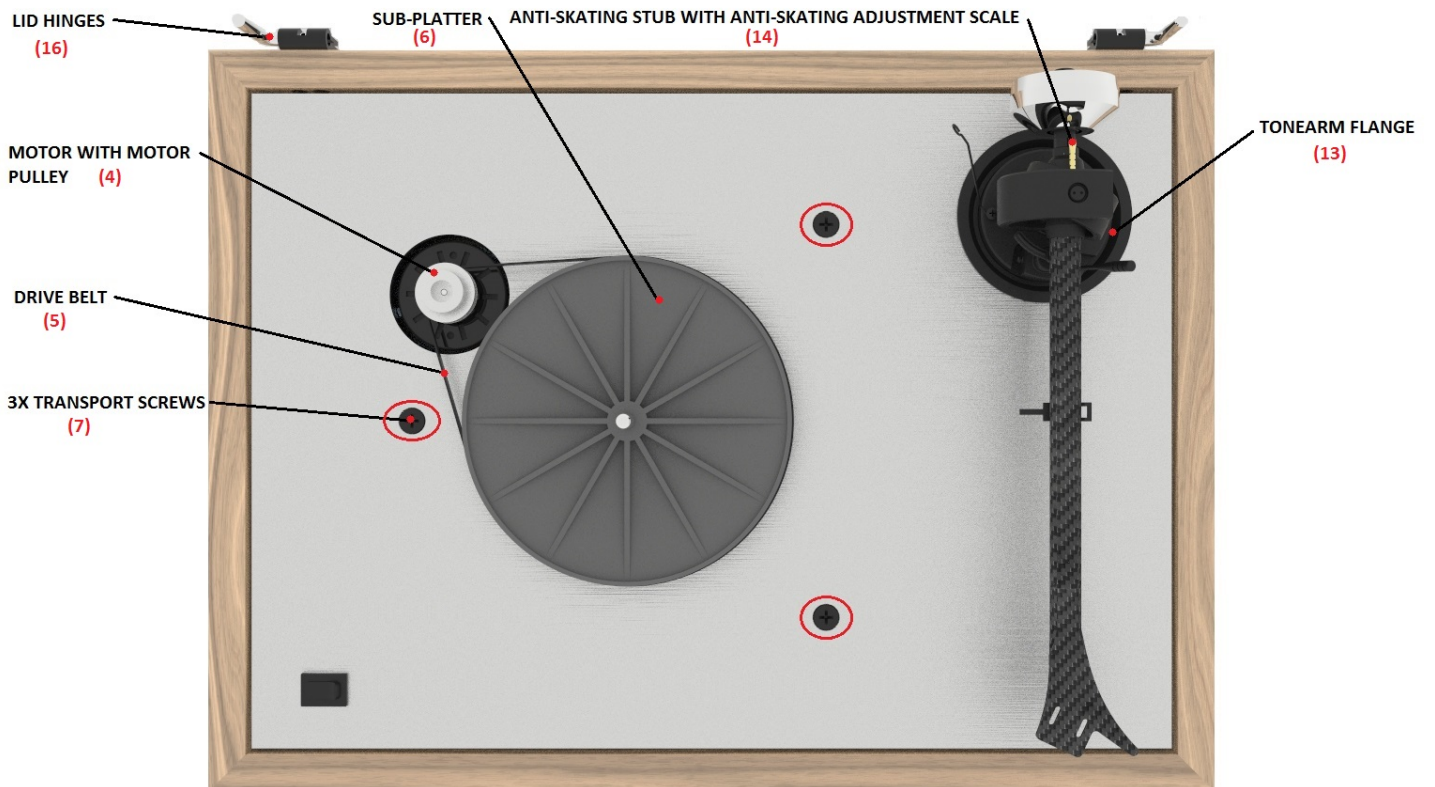

INSTRUCTIONS FOR USE  
The Classic

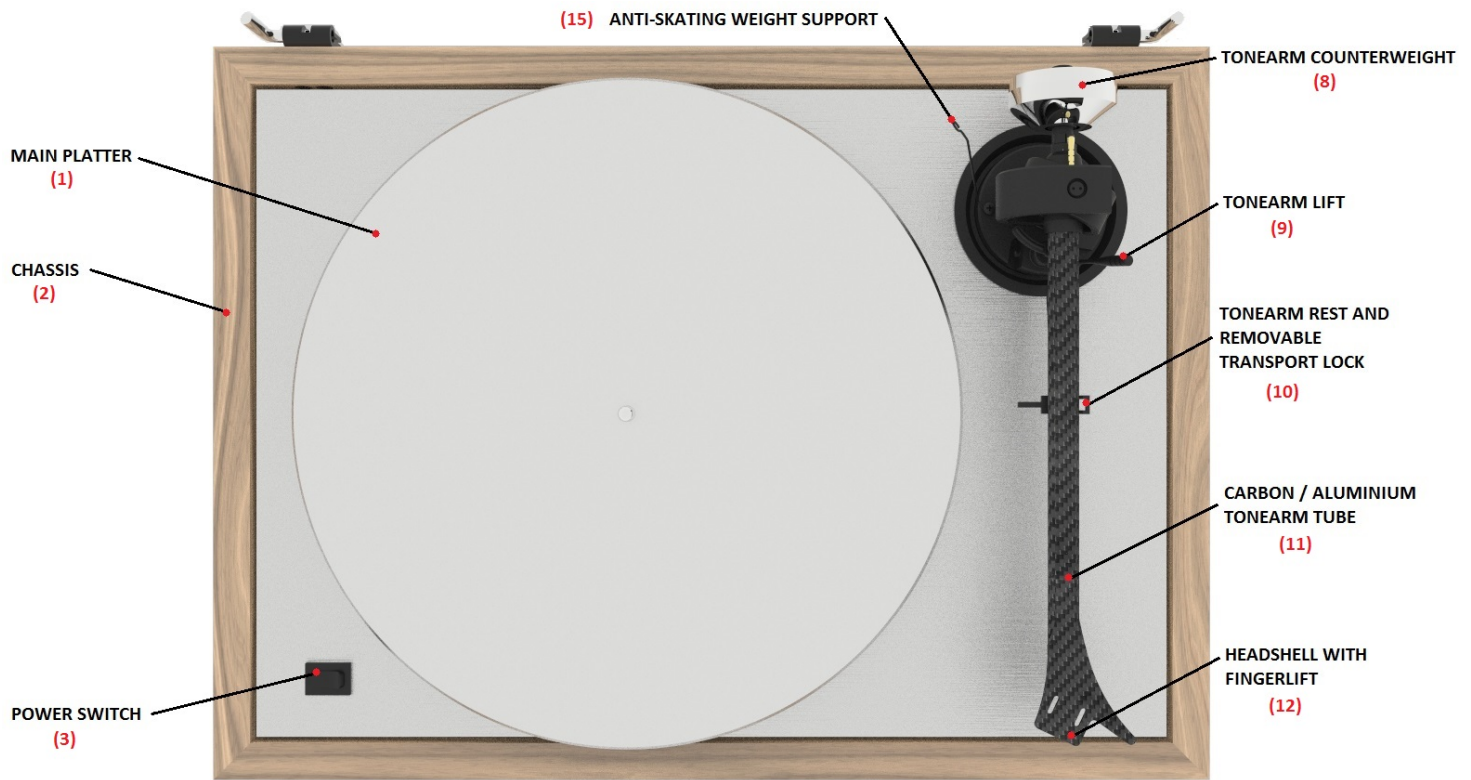

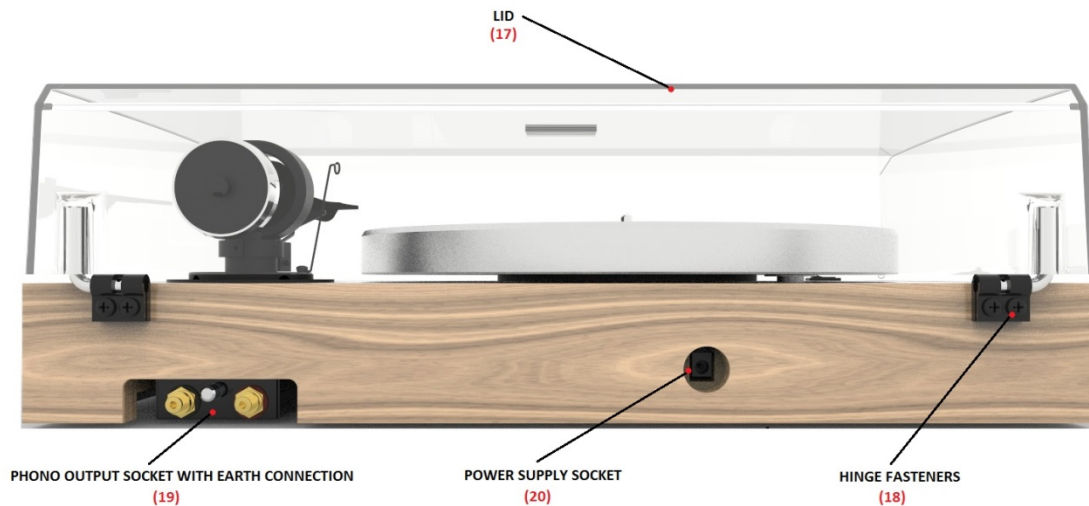

# Pro-Ject The Classic

AUDIO SYSTEMS

## Controls, features and connections

- (1) MAIN PLATTER
- (2) CHASSIS
- (3) POWER SWITCH
- (4) MOTOR WITH MOTOR PULLEY
- (5) DRIVE BELT
- (6) SUB-PLATTER
- (7) TRANSPORT SCREWS
- (8) TONEARM COUNTERWEIGHT
- (9) TONEARM LIFT
- (10) TONEARM REST AND REMOVABLE TRANSPORT LOCK
- (11) CARBON / ALUMINIUM TONEARM TUBE
- (12) HEADSHELL WITH FINGER LIFT
- (13) TONEARM FLANGE
- (14) ANTI-SKATING STUB WITH ANTI-SKATING ADJUSTMENT SCALE
- (15) ANTI-SKATING WEIGHT SUPPORT
- (16) LID HINGES
- (17) LID
- (18) HINGE FASTENERS
- (19) PHONO OUTPUT SOCKET
- (20) POWER SUPPLY SOCKET

## Turntable accessories

- (1) Instruction for use
- (2) Cartridge alignment protractor (not shown)
- (3) White cotton gloves
- (4) Anti-skating weight
- (5) Allen key 1.5mm
- (6) Allen key 2mm
- (7) Allen key 3mm
- (8) Counterweight no. **183** for cartridges with weight between 7 - 14g
- (9) Single adaptor
- (10) Hook tool
- (11) Stylus Pressure Gauge
- (12) Connect IT E RCA (not shown)
- (13) Cloth (not shown)
- (14) Power supply (not shown)

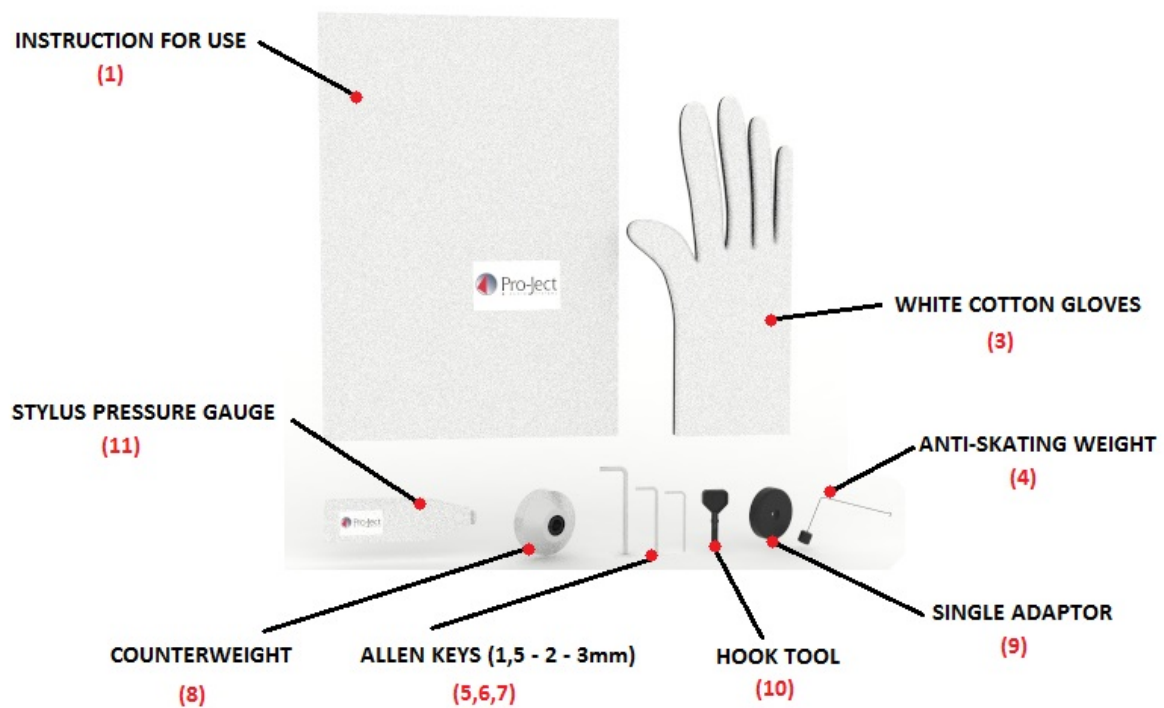

## CONTENTS

TURNTABLE OVERVIEW	2 - 3
ACCESSORIES OVERVIEW	4
<b>SETUP AND INSTALLATION</b>	
1. TRANSPORT CREWS	7
2. MOUNTING AND CONNECTING THE CARTRIDGE	8
3. CARTRIDGE DOWNFORCE ADJUSTMENT	8
4. ANTI-SKATING FORCE ADJUSTMENT	9
5. CONNECTION TO THE AMPLIFIER	9
6. MAINS POWER CONNECTION	10
7. FITTING THE LID	10
8. SWITCHING ON AND OFF	10
9. CHANGING REPLAY SPEED	10
10. ADJUSTING THE VERTICAL TRACKING ANGLE (VTA)	10
11. ADJUSTING THE AZIMUTH	11
12. USEFUL TIPS	11
13. MAINTENANCE AND CLEANING	11
TECHNICAL SPECIFICATIONS	12
WARRANTY, SERVICE	13
PACKAGING	14

Dear music lover,

thank you for purchasing a Pro-Ject Audio Systems record player.

In order to achieve maximum performance and reliability, please study these instructions carefully.



*Warning of a hazard for the user, the unit or possible misuse*



*Important notice*

The following instructions for adjusting the cartridge are provided in case the cartridge is replaced by a different model at a later date.

During assembling and adjustment small parts could be lost if they are not carefully placed in a suitable receptacle. Before starting assembly make yourself acquainted with the parts listed above which are correspondingly numbered in the technical drawings above. Separately packed items are marked with an asterisk \*.

## **Safety instructions**

*The power supply is used to connect and disconnect the unit from the mains. Make sure that the plug is easily accessible at all times. Hold the plug when unplugging the power cord. Never handle the power cord while your hands are wet or damp.*



*Avoid letting liquids enter the device. Never place any item containing liquid, like a flower vase, on or near the device. Never spill any liquid on the device. Never place any naked flame sources, like lighted candles, on or near the device. The product shall not be used in damp or wet locations, next to a bathtub, sink, swimming pool or any other similar conditions.*

*Keep plastic bags away from children to prevent any risk of suffocation.*

The turntable was shipped partially disassembled in order to avoid damage to sensitive parts. Please check immediately to make sure that neither the packaging nor the device was damaged in transit.

## **SETUP AND INSTALLATION**

### **1. TRANSPORT SCREWS**

Remove the three transport screws (7) from the upper part of the chassis before installing the sub-platter (6), the drive belt (5) and the platter (1).

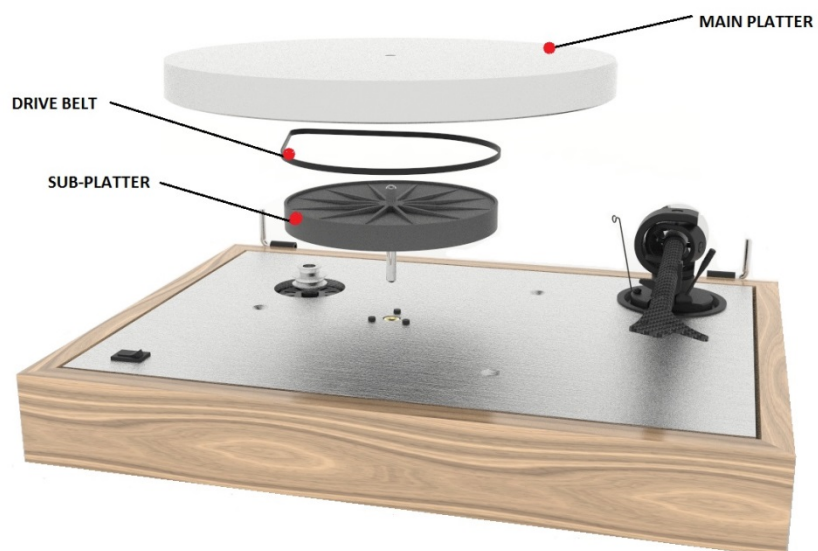
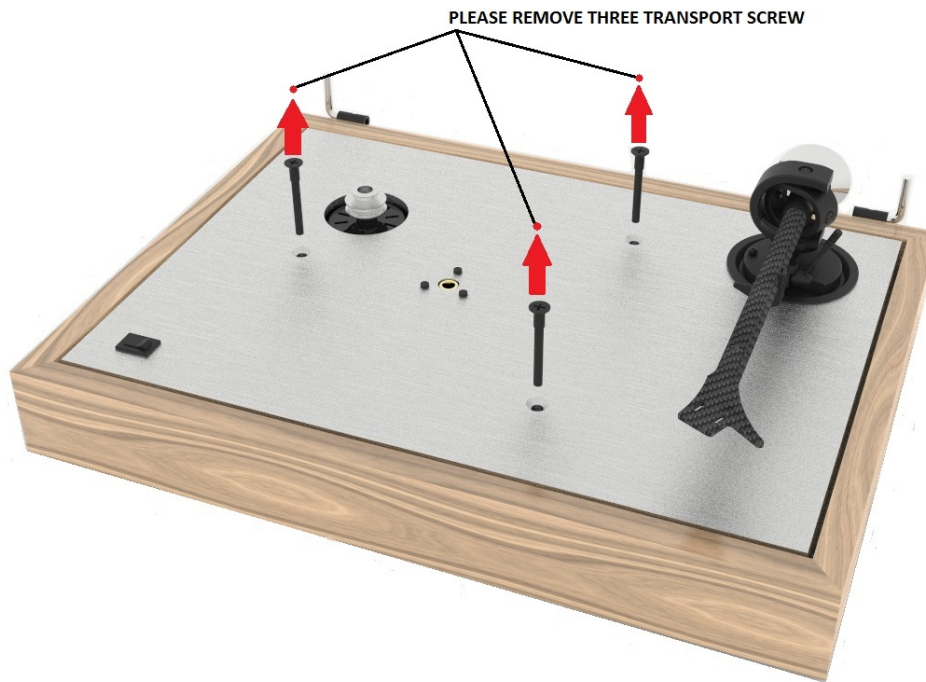

## 2. MOUNTING AND CONNECTING THE CARTRIDGE

All cartridges with half inch mounting holes can be mounted. Leave the needle's protection cover on, fit the cartridge to the headshell by using the supplied screws by passing one screw through each slot in the headshell (12). Do not tighten the nuts yet.

Connect the tonearm wires with the cartridge pins as follows:

white	left channel positive (L+)
red	right channel positive (R+)
green	right channel return (R -)
blue	left channel return (L -)

The full sound quality of the record player can only be achieved if the cartridge is adjusted correctly. Particular tools like the Pro-Ject Audio Systems alignment tool are required to accomplish this job properly. If you are not well acquainted with the adjustment of cartridges, please call for the willing help of your Pro-Ject Audio Systems dealer.



*Please note: adjusting a cartridge and tonearm calls for the greatest care in order to avoid damaging the cartridge or tonearm bearings. Ask your local dealer for help if you are unsure in any of the necessary steps and precautions which must be taken.*

## 3. CARTRIDGE DOWNFORCE ADJUSTMENT

The counterweight (8) supplied is suitable for cartridges weighing between 7 - 14g (counterweight no. 183). Adjust the downforce prior to setting the anti-skating force.

Place counterweight (8) halfway along the counterweight support rod at rear of arm, being sure to have the securing screw uppermost.

With the power off, and the platter static, place the stylus pressure gauge (13) onto the platter. To set the recommended 18mN downforce (1mN = 0,1g / 0,1 Pond), place the tip of the stylus exactly in-between the two points marked 15mN and 20mN.

If the stylus gauge becomes level, then the correct pressure has been achieved. However if there is insufficient or excessive pressure the gauge will either not move or tilt down.

To adjust the amount of pressure, carefully move the counterweight (8) along the support rod, until the stylus pressure is sufficient to raise the pressure gauge to the level position. Moving the counterweight (8) away from the cartridge will reduce pressure and towards will increase pressure.



*Please note: It is advised to remove stylus tip from gauge whilst making adjustments to avoid damage to stylus.*

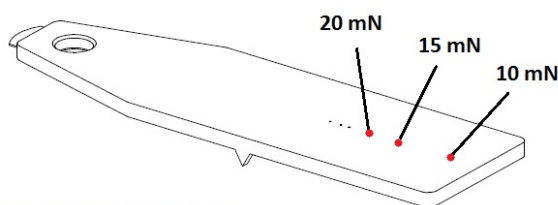

STYLUS PRESSURE GAUGE



#### 4. ANTI-SKATING FORCE ADJUSTMENT

Put the anti-skating thread hook over the anti-skating adjustment scale.

The anti-skating force must be adjusted corresponding to the downforce as follows:

<u>Downforce</u>	<u>Groove in the stub (15)</u>
10 - 14mN	1 <sup>st</sup> from bearing rings
15 - 19mN	2 <sup>nd</sup> " " "
20mN and bigger	3 <sup>rd</sup> " " "

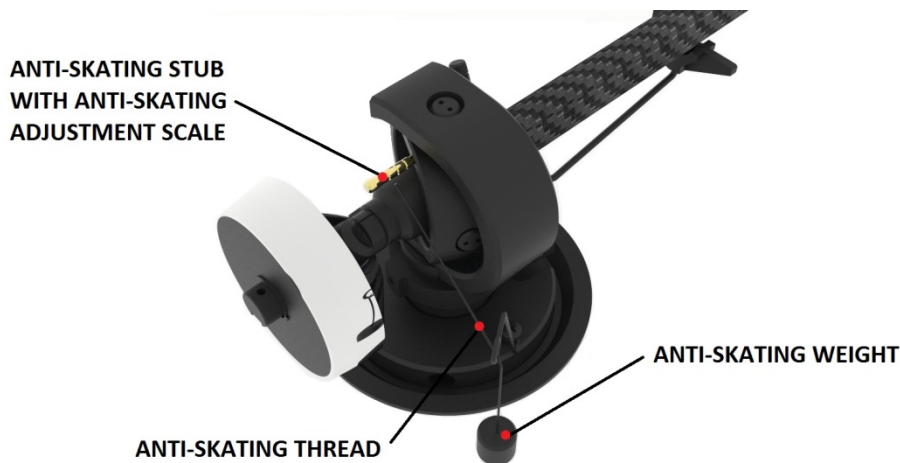
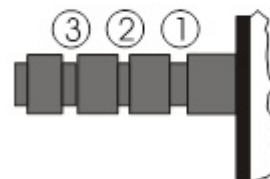

#### 5. CONNECTION TO THE AMPLIFIER

The record player has gold plated female RCA phono sockets (19) so you can substitute the interconnect cables supplied with higher quality cables such as the **Pro-Ject Connect it C/CC/Si** interconnect cables for connection to the amplifier if you wish. Use the **Phono** input (sometimes labelled gram, disc or RIAA) on your amplifier. Make sure that the phono input offers correct matching and amplification for the type of cartridge used. Line inputs (like CD, Tuner, Tape or Video) are not suitable.

Take care about connecting the left and right channel correctly. The **RIGHT CHANNEL** is usually marked **RED**, the **LEFT CHANNEL BLACK** or **WHITE**. Check the manual of your amplifier for relevant information. An earthing wire may be connected to the screw terminal between the sockets if you encounter humming problems.

If your amplifier does not have an input suitable for phono cartridges, a separate phono amplifier stage for MM or MC cartridges is required. It has to be connected between record player and a free line level input of the amplifier.

For detailed product information regarding Pro-Ject Audio Systems interconnect cables and phono amplifiers please visit our website: [www.project-audio.com](http://www.project-audio.com)

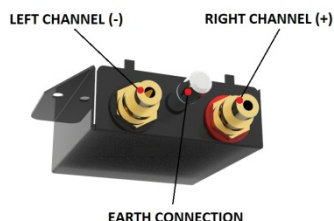

## 6. MAINS POWER CONNECTION

The turntable is supplied with a power supply suitable for your country's mains supply. Check the label before connecting to ensure compliance with the mains rating in your house.



Connect the low voltage plug from the power supply to the socket (20) on the rear of the record player before connecting the power supply to the mains.

## 7. FITTING THE LID

Fit the lid (dust cover 17) carefully over the hinge prongs and adjust the screws (18) until the lid stays open where you want it to without being too stiff to open or close.

## 8. SWITCHING ON AND OFF

Pressing the power switch (3) alternately starts or stops the motor.

## 9. CHANGING REPLAY SPEED

To play records at 45 r.p.m., put the drive belt (5) over the larger diameter part of the motor pulley (4) using the accessory tool provided (10 – accessories list). To revert to 33 r.p.m. repeat the proceedings using the smaller step on the pulley.

## 10. ADJUSTING THE VERTICAL TRACKING ANGLE (VTA)

Put a record on the platter. When the needle is lowered into the record groove and the tonearm is not resting on the lift arm, the tube of the tonearm should be parallel to the surface of the record.

If it is not, loosen both hexagon screws in the tonearm base just enough to allow vertical movement of the arm pillar without force and slide the arm up or down until it is parallel.

Retighten the hexagon screws without applying excessive force (which would deform the arm pillar) – finger tight is quite sufficient.



## 11. ADJUSTING THE AZIMUTH

The cartridge needle must be vertical in the record groove in order to trace the groove wall modulations correctly.

A small screw at the bearing end of the arm allows incorrect azimuth to be corrected.

Slacken off the screw just enough to be able to revolve the arm tube without applying force. Note! Do not remove this screw completely!

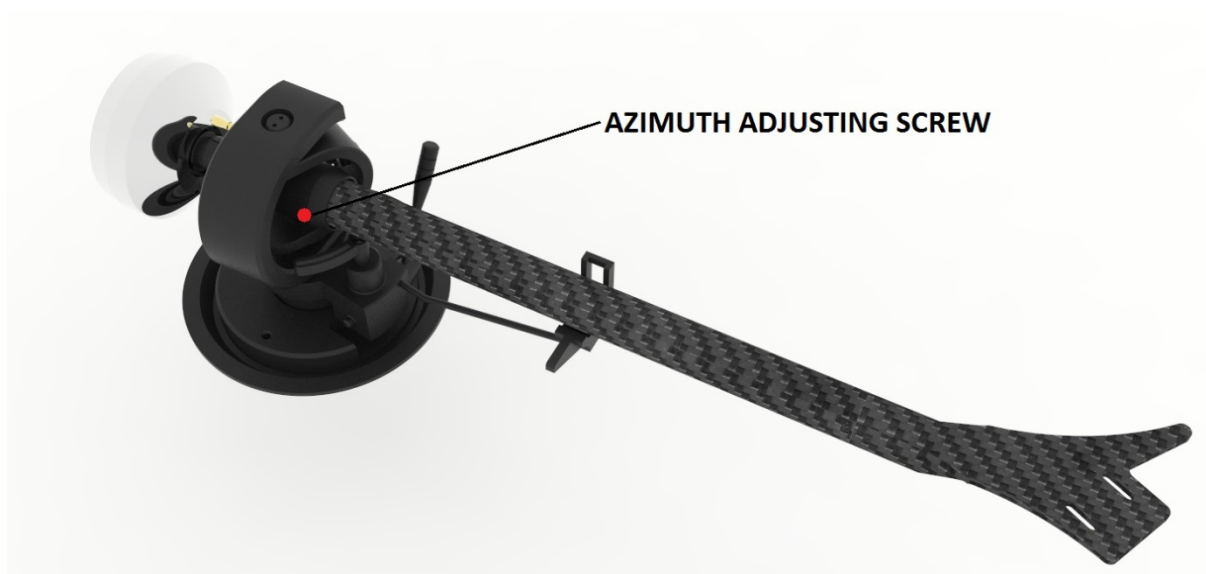

## 12. USEFUL TIPS

The lid is not only a dust cover but also a resonant structure likely to be excited by and to pass into the plinth the acoustic energy emanating from your loudspeakers during replay. Therefore it is recommended to remove the lid for achieving a better sound quality. The record player should be positioned on a low-resonance surface, like wood or multiple layer ply board to avoid structural vibrations disturbing replay.

## 13. MAINTENANCE AND CLEANING

Your record player requires little or no regular maintenance. Remove dust with a slightly moistened antistatic cloth. Never use a dry cloth because this will create static electricity which attracts even more dust! Antistatic cleaning fluids are available at specialized stores but must be applied sparingly to avoid damage to rubber parts. It is recommended to fit the needle cover before cleaning or maintenance to avoid damage.

If the player is not used over a long period of time, the drive belt should be removed to prevent unequal stretching.



*Always disconnect the record player from the mains power supply as a precaution before maintenance!*

## TECHNICAL SPECIFICATIONS

### Pro-Ject THE CLASSIC with Pro-Ject 9'' Carbon/Alu sandwich tonearm

Nominal speeds	33/45 r.p.m.
Speed variance	33: $\pm 0,15$ % 45: $\pm 0,12$ %
Wow and flutter	33: $\pm 0,11$ % 45: $\pm 0,10$ %
Signal to noise	70dB
Effective tonearm mass	13,5g
Effective tonearm length	9 " (230mm)
Overhang	18mm
Power consumption	5W/ >0,5W standby mode
Outboard power supply	15V/ 1,6 A DC, universal power supply
Dimensions (W x H x D)	462 x 131 x 351mm, dust cover open 462 x 423 x 390mm
Weight	10,2 kg

### Technical specifications MM-Cartridge Ortofon 2M Silver

Frequency range	20-22.000Hz
Channel separation	23dB/1kHz
Output voltage	4mV
Recommended load impedance	47kohms/amplifier connection – MM-input
Compliance/stylus type	20 $\mu$ m/mN – elliptical
Recommended tracking force	18mN
Weight	7,2g

## Potential incorrect use and fault conditions

Pro-Ject turntables are manufactured to the highest standards and undergo strict quality controls before leaving the factory. Faults that may possibly occur are not necessarily due to material or production faults but can sometimes be caused by incorrect use or unfortunate circumstances. Therefore the following list of common fault symptoms is included.

### The platter doesn't turn although the unit is switched on:

- The unit is not connected to the mains power supply.
- No mains at the socket.
- Drive belt is not fitted or has slipped off.

### No signal through one or other channel or both channels:

- No signal contact from the cartridge to the internal tonearm wiring or from that to the arm lead or from that to the phono box or between that and the amplifier. This could be due to a faulty plug, broken wire or solder joint or simply loose plug/socket connection.
- Phono input not selected at amplifier.
- Amplifier is not switched on.
- Amplifier or speakers are defective or muted.
- No connection to the loudspeakers.

### Strong hum on phono input:

- No earth connection from cartridge or arm or arm cable to amplifier, or earth loop.

### Distorted or inconsistent sound from one or both channels:

- Record player is connected to wrong input of amplifier, or MM/MC switch incorrectly set.
- Needle or cantilever damaged.
- Wrong r.p.m., drive belt overstretched or dirty, platter bearing without oil, dirty or damaged.

## Service

Should you encounter a problem which you are not able to alleviate or identify despite the above information, please contact your dealer for further advice. Only when the problem cannot be resolved there should the unit be sent to the responsible distributor in your country.

Guarantee repairs will only be affected if the unit is returned correctly packaged. For this reason we recommend keeping the original packaging.

Never return a record player without making sure that it is safely disassembled and correctly packaged in the original packaging according to the diagrams on the last page of this user guide. Please remove these parts and pack them separately: lid, counterweight, anti-skating weight, platter and belt. Fit the cartridge protection cap. Insert the transport screws for the sub-chassis, the transport lock for the tonearm prior to carefully packaging the record player.

## Warranty



*The manufacturer accepts no responsibility for damage caused by not adhering to these instructions for use and/or by transportation without the original packaging. Modification or change to any part of the product by unauthorized persons, release the manufacturer from any liability over and above the lawful rights of the customer.*

Pro-Ject Audio Systems is a Registered Trademark of H. Lichtenegger.

This guide was produced by: Pro-Ject Audio Systems  
Copyright © 2016. All rights reserved.

The information was correct at the time of going to press. The manufacturer reserves the right to make changes to the technical specification without prior notice as deemed necessary to uphold the ongoing process of technical development.

